

FOR EXPLANATION OF DIMENSIONING ETC., SEE BS 8888.  
 UNLESS OTHERWISE STATED:-  
 (1) ALL BURRS & SHARP EDGES TO BE REMOVED BY 0.5 MAX. CHAMFER OR RADIUS. (2) ALL INTERNAL CORNERS TO BE FORMED BY A 0.5/0.2 RADIUS OR CHAMFER. (3) REFERENCES TO STANDARDS & SPECS. INFER LATEST ISSUE. (4) SURFACE ROUGHNESS  $\sqrt{Ra}$  T.6 UNLESS OTHERWISE STATED.

© SYSTEMS LTD OWNS THE COPYRIGHT IN THIS DOCUMENT. IT IS SUPPLIED IN CONFIDENCE AND MUST NOT BE USED FOR ANY PURPOSE OTHER THAN THAT FOR WHICH IT HAS BEEN ISSUED. IT MUST NOT BE REPRODUCED EITHER IN WHOLE OR IN PART WITHOUT THE WRITTEN PERMISSION OF THE COPYRIGHT HOLDER.

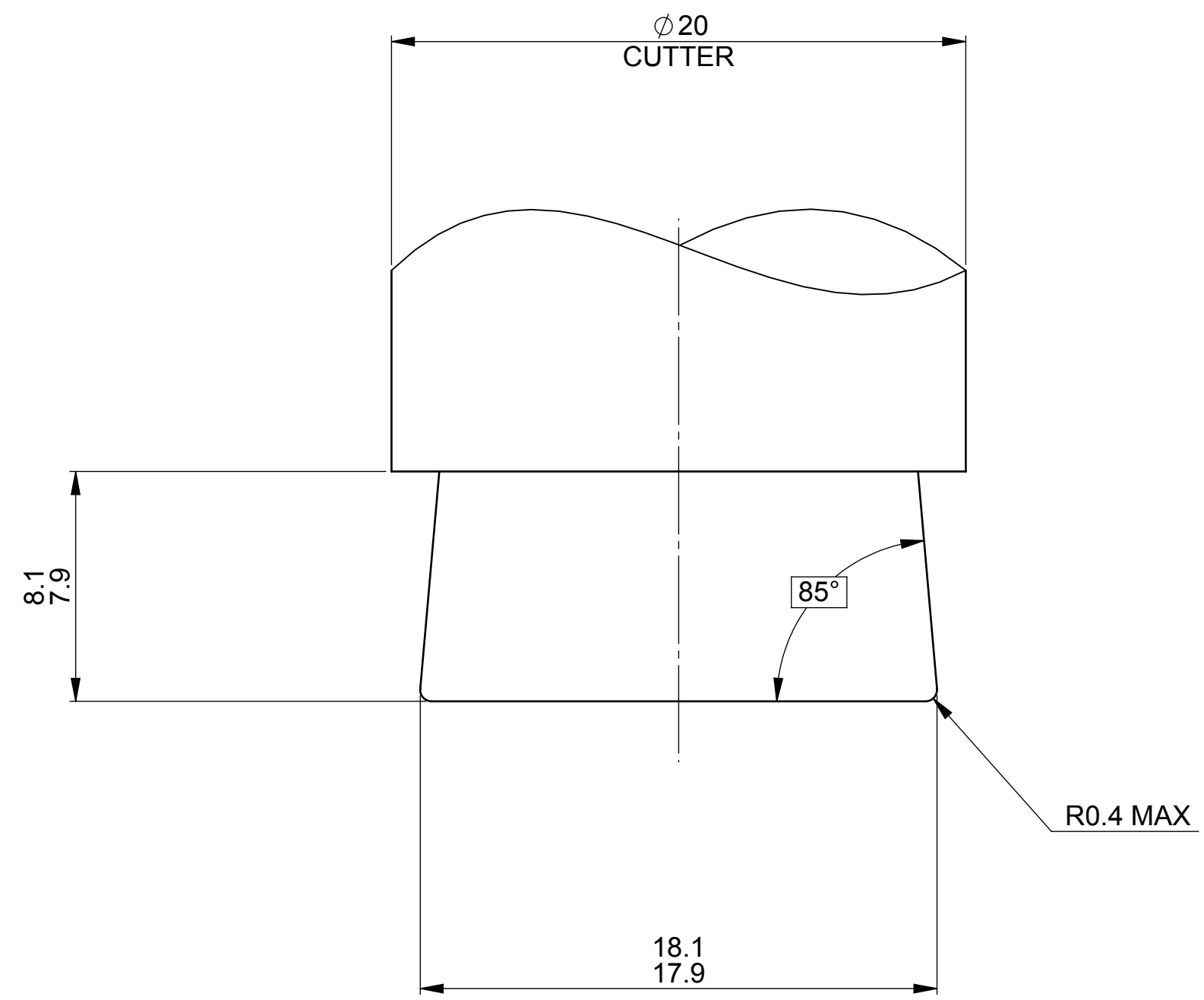

TITLE:  
**BLOCK VELOCITY TOOL  
 85 DEG CUTTER**

CONTRACTOR:

DRG No:  
**13780**

ISSUE:

N.S.N:

SECURITY CLASSIFICATION:  
**UNCLASSIFIED**